

[Home](#)[Company profile](#)[Products show](#)[Trade show](#)[Query](#)[Download](#)[Contact us](#)

### Lift tools & Handling Equipments

- ※Chain blocks
- ※Lever blocks
- ※Plain (Geared) trolley
- ※Lifting clamps & lifters
- ※Wire Block & Snatch Block
- ※Air Hoist
- ※Pallet truck and Fork Lift
- ※Jack series
- ※Hand winch,Grip & puller

[Home](#) > [Products Show](#) > [Low Headroom Electric Hoist With Motor Trolley](#)

## Low Headroom Electric Hoist With Motor Trolley

[Low Headroom Electric Hoist With Motor Trolley](#)

- ※Wire rope hoist,Cutter and Bender
- ※Permanent Magnet Lifter and Digital Scale
- ※Gantry crane
- ※Spreader Beam

**Electric Hoist**

- ※Electric Chain Hoist
- ※Electric Wire Rope Hoist
- ※Electric Windlass
- ※Electric winch
- ※MINI Electric Wire Hoist

**webbing sling**

- ※webbing sling
- ※Ratchet/ Cambuckle Tie Downs
- ※Luggage Strap Series
- ※Tow Rope Series
- ※Safety Harness Series

**Rigging hardwares**

- ※Shackles
- ※Wire rope clips
- ※Turnbuckles
- ※Load binders
- ※Bolts and Swivels
- ※G80 components
- ※Alloy steel chain G80 & Chain Sling
- ※Ordinary Chain
- ※Stainless Steel Link Chain
- ※Wire Rope Thimbles
- ※Pulleys
- ※Socket and Sleeve
- ※Snap Hook and Rigging Hardware
- ※Stainless Steel Rigging Hardware
- ※G100 Accessories

**Steel wire ropes**

- ※Steel wire ropes
- ※Stainless steel wire rope

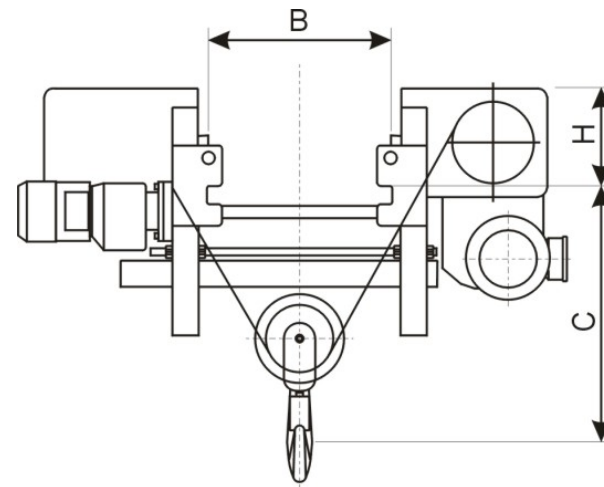

Capacity (kg)	Lifting Height m	Lifting Speed (m/min)	Lifting Power KW	Travelling Speed m/min	Travelling Power (kw)	Working Group FEM/ISO	Traveling Working Group FEM/ISO	H (mm)	C (mm)	I-beam B(mm)	Weight kg
2000	6	5/0.8	3.2/0.45	5/20	0.37	3M M6	2M M5	210	556	150-300	341
	9	5/0.8	3.2/0.45	5/20	0.37	3M M6	2M M5	210	556	150-300	360
	12	5/0.8	3.2/0.45	5/20	0.37	3M M6	2M M5	210	556	150-300	380
	15	5/0.8	3.2/0.45	5/20	0.37	3M M6	2M M5	210	556	150-300	401
	18	5/0.8	3.2/0.45	5/20	0.37	3M M6	2M M5	210	556	150-300	425
3200	6	5/0.8	3.2/0.45	5/20	0.37	2M M5	2M M5	210	556	150-300	346
	9	5/0.8	3.2/0.45	5/20	0.37	2M M5	2M M5	210	556	150-300	363
	12	5/0.8	3.2/0.45	5/20	0.37	2M M5	2M M5	210	556	150-300	385
	15	5/0.8	3.2/0.45	5/20	0.37	2M M5	2M M5	210	556	150-300	406
	18	5/0.8	3.2/0.45	5/20	0.37	2M M5	2M M5	210	556	150-300	428
5000	6	5/0.8	6.1/1	5/20	0.37	2M M5	2M M5	260	596	200-350	413
	9	5/0.8	6.1/1	5/20	0.37			260	596	200-	435

**Tools of Electricity**

※STRINGING BLOCK

※HOISTING TACKLE

※GRIPPING CLAMPS

※CABLE AND SOCK

※WINCH

※ROLLER

※PRESS TOOLS AND CUTTER

						2M M5	2M M5			350	
	12	5/0.8	6.1/1	5/20	0.37	2M M5	2M M5	260	596	200-350	462
	15	5/0.8	6.1/1	5/20	0.37	2M M5	2M M5	260	596	200-350	489
	18	5/0.8	6.1/1	5/20	0.37	2M M5	2M M5	260	596	200-350	516
6300	6	5/0.8	6.1/1	5/20	0.37	1Am M4	2M M5	260	596	200-350	413
	9	5/0.8	6.1/1	5/20	0.37	1Am M4	2M M5	260	596	200-350	435
	12	5/0.8	6.1/1	5/20	0.37	1Am M4	2M M5	260	596	200-350	462
	15	5/0.8	6.1/1	5/20	0.37	1Am M4	2M M5	260	596	200-350	489
	18	5/0.8	6.1/1	5/20	0.37	1Am M4	2M M5	260	596	200-350	516
8000	6	5/0.8	9.5/1.5	5/20	0.75	3M M6	2M M5	325	750	200-410	814
	9	5/0.8	9.5/1.5	5/20	0.75	3M M6	2M M5	325	750	200-410	846
	12	5/0.8	9.5/1.5	5/20	0.75	3M M6	2M M5	325	750	200-410	890
	15	5/0.8	9.5/1.5	5/20	0.75	3M M6	2M M5	325	750	200-410	934
	18	5/0.8	9.5/1.5	5/20	0.75	3M M6	2M M5	325	750	200-410	978
10000	6	5/0.8	9.5/1.5	5/20	0.75	2M M5	2M M5	325	750	200-410	814
	9	5/0.8	9.5/1.5	5/20	0.75	2M M5	2M M5	325	750	200-410	846
	12	5/0.8	9.5/1.5	5/20	0.75	2M M5	2M M5	325	750	200-410	890
	15	5/0.8	9.5/1.5	5/20	0.75	2M M5	2M M5	325	750	200-410	934
	18	5/0.8	9.5/1.5	5/20	0.75	2M M5	2M M5	325	750	200-410	978
12500	6	4/0.6	12.5/2	5/20	0.75	1Am M4	2M M5	325	750	200-410	814
	9	4/0.6	12.5/2	5/20	0.75	1Am M4	2M M5	325	750	200-410	846
	12	4/0.6	12.5/2	5/20	0.75	1Am M4	2M M5	325	750	200-410	890
	15	4/0.6	12.5/2	5/20	0.75	1Am M4	2M M5	325	750	200-	934

										410	
	18	4/0.6	12.5/2	5/20	0.75	1Am M4	2M M5	325	750	200-410	978
16000	6	4/0.6	16/2.6	5/20	0.75x2	2M M5	2M M5	400	920	300-450	958
	9	4/0.6	16/2.6	5/20	0.75x2	2M M5	2M M5	400	920	300-450	1042
	12	4/0.6	16/2.6	5/20	0.75x2	2M M5	2M M5	400	920	300-450	1166
	15	4/0.6	16/2.6	5/20	0.75x2	2M M5	2M M5	400	920	300-450	1286
	18	4/0.6	16/2.6	5/20	0.75x2	2M M5	2M M5	400	920	300-450	1406
20000	6	4/0.6	16/2.6	5/20	0.75x2	1Am M4	2M M5	400	920	300-450	958
	9	4/0.6	16/2.6	5/20	0.75x2	1Am M4	2M M5	400	920	300-450	1042
	12	4/0.6	16/2.6	5/20	0.75x2	1Am M4	2M M5	400	920	300-450	1166
	15	4/0.6	16/2.6	5/20	0.75x2	1Am M4	2M M5	400	920	300-450	1286
	18	4/0.6	16/2.6	5/20	0.75x2	1Am M4	2M M5	400	920	300-450	1406
8000	20	8/1.3	16/2.6	5/20	0.75	2M M5	2M M5	325	750	200-410	1019
	24	8/1.3	16/2.6	5/20	0.75	2M M5	2M M5	325	750	200-410	1060
	28	8/1.3	16/2.6	5/20	0.75	2M M5	2M M5	325	750	200-410	1101
	32	8/1.3	16/2.6	5/20	0.75	2M M5	2M M5	325	750	200-410	1142
	36	8/1.3	16/2.6	5/20	0.75	2M M5	2M M5	325	750	200-410	1183
10000	20	8/1.3	16/2.6	5/20	0.75	2M M5	2M M5	325	750	200-410	1019
	24	8/1.3	16/2.6	5/20	0.75	2M M5	2M M5	325	750	200-410	1060
	28	8/1.3	16/2.6	5/20	0.75	2M M5	2M M5	325	750	200-410	1101
	32	8/1.3	16/2.6	5/20	0.75	2M M5	2M M5	325	750	200-410	1142
	36	8/1.3	16/2.6	5/20	0.75	2M M5	2M M5	325	750	200-410	1183
12500	20	6.3/1	16/2.6	5/20	0.75	1Am M4	2M M5	325	750	200-	1019

										410	
24	6.3/1	16/2.6	5/20	0.75	1Am M4	2M M5	325	750	200-410	1060	
28	6.3/1	16/2.6	5/20	0.75	1Am M4	2M M5	325	750	200-410	1101	
32	6.3/1	16/2.6	5/20	0.75	1Am M4	2M M5	325	750	200-410	1142	
36	6.3/1	16/2.6	5/20	0.75	1Am M4	2M M5	325	750	200-410	1183	

[Home](#)
[Company profile](#)
[Products show](#)
[Trade show](#)
[Query](#)
[Download](#)
[Contact us](#)

Copyright© TOHO-RONGKEE ELECTRONIC & MACHINERY CO.,LTD All Rights Reserved.